

TYPICAL ELEVATIONS

**RAMPART SERIES 5500
ALUMINUM WINDOW WALL SYSTEM (S.M.I.)**

THIS PRODUCT HAS BEEN DESIGNED AND TESTED TO COMPLY WITH THE REQUIREMENTS OF THE 2020 (7TH EDITION)/2023 (8TH EDITION) FLORIDA BUILDING CODE INCLUDING HIGH VELOCITY HURRICANE ZONE (HVHZ).

1BY OR 2BY WOOD BUCKS & BUCK FASTENERS BY OTHERS, MUST BE DESIGNED AND INSTALLED ADEQUATELY TO TRANSFER APPLIED PRODUCT LOADS TO THE BUILDING STRUCTURE.

ANCHORS SHALL BE CORROSION RESISTANT, SPACED AS SHOWN ON DETAILS AND INSTALLED PER MANUF'S INSTRUCTIONS. SPECIFIED EMBEDMENT TO BASE MATERIAL SHALL BE BEYOND WALL DRESSING OR STUCCO.

A LOAD DURATION INCREASE IS USED IN DESIGN OF ANCHORS INTO WOOD ONLY.

ALL SHIMS TO BE HIGH IMPACT, NON-METALLIC AND NON-COMPRESSIBLE.

MATERIALS INCLUDING BUT NOT LIMITED TO STEEL/METAL SCREWS, THAT COME INTO CONTACT WITH OTHER DISSIMILAR MATERIALS SHALL MEET THE REQUIREMENTS OF THE 2020/2023 FLORIDA BLDG. CODE & ADOPTED STANDARDS.

THIS PRODUCT APPROVAL IS GENERIC AND DOES NOT PROVIDE INFORMATION FOR A SITE SPECIFIC PROJECT, I.E. LIFE SAFETY OF THIS PRODUCT, ADEQUACY OF STRUCTURE RECEIVING THIS PRODUCT AND SEALING AROUND OPENING FOR WATER INFILTRATION RESISTANCE ETC. CONDITIONS NOT SHOWN IN THIS DRAWING ARE TO BE ANALYZED SEPARATELY, AND TO BE REVIEWED BY BUILDING OFFICIAL.

DESIGN LOADS SHOWN ARE BASED ON 'ALLOWABLE STRESS DESIGN (ASD)'.

MANUFACTURER'S LABEL SHALL BE LOCATED ON A READILY VISIBLE LOCATION IN ACCORDANCE WITH SECTION 1709.9.3 OF FLORIDA BUILDING CODE. LABELING TO COMPLY WITH SECTION 1709.9.2.

INSTRUCTIONS:

USE CHARTS AS FOLLOWS.

- STEP 1** DETERMINE DESIGN WIND PRESSURE REQUIREMENTS BASED ON WIND VELOCITY, BLDG. HEIGHT, WIND ZONE USING APPLICABLE ASCE 7 STANDARD.
- STEP 2** CHECK DESIGN LOAD CAPACITY FOR A GIVEN SPACING AND HEIGHT USING CHARTS ON SHEET 2 THE CAPACITY SHOULD EXCEED THE DESIGN LOAD.
- STEP 3** USING CHARTS ON SHEET 3 SELECT ANCHOR OPTION WITH DESIGN LOAD CAPACITY MORE THAN DESIGN LOAD SPECIFIED IN STEP 1 ABOVE.
- STEP 4** THE LOWEST VALUE RESULTING FROM STEPS 2 AND 3 THAT EXCEED THE DESIGN WIND PRESSURES DETERMINED THRU STEP 1 SHALL APPLY TO ENTIRE SYSTEM.
- STEP 5** FOR SYSTEMS WITH UNANCHORED JAMBS, USING SHEET 5, DETERMINE THE MIN. & MAX. GAP DIMENSIONS.

DAYLITE OPENINGS SINGLE 'O' PANEL:

DLO WIDTH = FRAME WIDTH - 4.50"
DLO HEIGHT = FRAME HEIGHT - 5.50"

PRODUCT COMPLIES WITH REQUIREMENTS OF ANSI Z97.1.

THIS SYSTEM IS RATED FOR SMALL MISSILE IMPACT.
F.B.C. APPROVED IMPACT RESISTANT SHUTTERS REQUIRED FOR INSTALLATIONS UP TO 30 FT. OF GRADE.
SHUTTERS NOT REQD. FOR INSTALLATIONS ABOVE 30 FT. OF GRADE.

Sealed: 7/12/2023 FL #21899

- A- CONTRACTOR TO BE RESPONSIBLE FOR THE SELECTION, PURCHASE AND INSTALLATION OF THIS PRODUCT BASED ON THIS PRODUCT EVALUATION PROVIDED HE/SHE DOES NOT DEVIATE FROM THE CONDITIONS DETAILED ON THIS DOCUMENT.
- B- THIS PRODUCT EVALUATION DOCUMENT WILL BE CONSIDERED INVALID IF ALTERED BY ANY MEANS.
- C- SITE SPECIFIC PROJECTS SHALL BE PREPARED BY A FLORIDA REGISTERED ENGINEER OR ARCHITECT WHICH WILL BECOME THE ENGINEER OF RECORD (E.O.R.) FOR THE PROJECT AND WHO WILL BE RESPONSIBLE FOR THE PROPER USE OF THE P.E.D. ENGINEER OF RECORD, ACTING AS A DELEGATED ENGINEER TO THE P.E.D. ENGINEER SHALL SUBMIT TO THIS LATTER THE SITE SPECIFIC DRAWINGS FOR REVIEW.
- D- THIS P.E.D. SHALL BEAR THE DATE AND ORIGINAL SEAL AND SIGNATURE OF THE PROFESSIONAL ENGINEER OF RECORD THAT PREPARED IT.

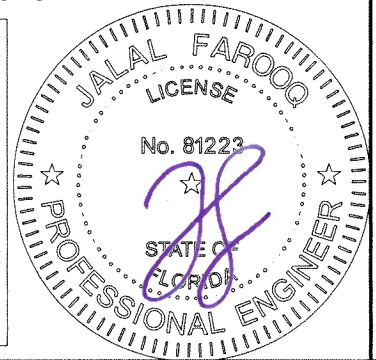

af c
AL-FAROOQ CORPORATION
ENGINEERS & PRODUCT DEVELOPMENT
9360 SUNSET DRIVE, SUITE 220
MIAMI, FLORIDA 33173 (C.A.N. 3538)
TEL. (305) 264-8100 FAX. (305) 262-6978
COMP-ANL \ W16-68ECS

RAMPART SERIES 5500 WINDOW WALL (S.M.I.)
EGS INTERNATIONAL, LLC
2799 SW 34th Avenue
Pembroke Park, FL 33023
Phone: (954) 519-7536 www.egsinternationalllc.com

no.	date	by	description
A	11.17.17		UPDATED TO 2017 FBC
B	10.30.20		UPDATED TO 2020 FBC
C	06.21.23		UPDATED TO 2023 FBC

date: 11-05-16
scale: 1/2"=1'-0"
dr. by: TARIQ
chk. by:

drawing no.
W16-68

sheet 1 of 7

DESIGN LOAD CAPACITY - PSF							
NOMINAL DIMS.		JAMB 'J1'		MULLION 'M1'		MULLION 'M2'	
WIDTH (W)	FRAME HEIGHT	EXT.(+)	INT.(-)	EXT.(+)	INT.(-)	EXT.(+)	INT.(-)
36"	72"	100.0	130.0	100.0	130.0	100.0	130.0
42"		100.0	130.0	100.0	130.0	100.0	130.0
48"		100.0	130.0	100.0	130.0	100.0	130.0
54"		100.0	130.0	100.0	130.0	100.0	130.0
60"		100.0	130.0	100.0	130.0	100.0	130.0
66"		90.9	118.2	90.9	118.2	90.9	118.2
72"		83.3	108.3	83.3	108.3	83.3	108.3
36"	78"	100.0	130.0	100.0	130.0	100.0	130.0
42"		100.0	130.0	100.0	130.0	100.0	130.0
48"		100.0	130.0	100.0	130.0	100.0	130.0
54"		100.0	130.0	100.0	130.0	100.0	130.0
60"		100.0	130.0	100.0	130.0	100.0	130.0
66"		90.9	118.2	90.9	118.2	90.9	118.2
72"		83.3	108.3	83.3	108.3	83.3	108.3
36"	84"	100.0	130.0	100.0	130.0	100.0	130.0
42"		100.0	130.0	100.0	130.0	100.0	130.0
48"		100.0	130.0	100.0	130.0	100.0	130.0
54"		100.0	130.0	100.0	130.0	100.0	130.0
60"		100.0	130.0	100.0	130.0	100.0	130.0
66"		90.9	118.2	90.9	118.2	90.9	118.2
72"		83.3	108.3	83.3	108.3	83.3	108.3
36"	90"	100.0	130.0	100.0	130.0	100.0	130.0
42"		100.0	130.0	100.0	130.0	100.0	130.0
48"		100.0	130.0	100.0	130.0	100.0	130.0
54"		100.0	130.0	100.0	130.0	100.0	130.0
60"		100.0	130.0	100.0	130.0	100.0	130.0
66"		90.9	118.2	90.9	118.2	90.9	118.2
72"		83.3	108.3	83.3	108.3	83.3	108.3
36"	96"	100.0	130.0	100.0	130.0	100.0	130.0
42"		100.0	130.0	100.0	130.0	100.0	130.0
48"		100.0	130.0	100.0	130.0	100.0	130.0
54"		100.0	130.0	100.0	130.0	100.0	130.0
60"		100.0	130.0	100.0	130.0	100.0	130.0
66"		90.9	118.2	90.9	118.2	90.9	118.2
72"		83.3	108.3	83.3	108.3	83.3	108.3
36"	102"	100.0	130.0	100.0	130.0	100.0	130.0
42"		100.0	130.0	100.0	130.0	100.0	130.0
48"		100.0	130.0	100.0	130.0	100.0	130.0
54"		100.0	130.0	100.0	130.0	100.0	130.0
60"		100.0	130.0	100.0	130.0	100.0	130.0
66"		90.9	118.2	90.9	118.2	90.9	118.2
72"		83.3	108.3	83.3	108.3	83.3	108.3
36"	108"	100.0	130.0	100.0	130.0	100.0	130.0
42"		100.0	130.0	100.0	130.0	100.0	130.0
48"		100.0	130.0	100.0	130.0	100.0	130.0
54"		100.0	130.0	100.0	130.0	100.0	130.0
60"		100.0	130.0	100.0	130.0	100.0	130.0
66"		90.9	118.2	90.9	118.2	90.9	118.2
72"		83.3	108.3	83.3	108.3	83.3	108.3
36"	114"	100.0	130.0	100.0	130.0	100.0	130.0
42"		100.0	130.0	100.0	130.0	100.0	130.0
48"		100.0	130.0	100.0	130.0	100.0	130.0
54"		100.0	130.0	100.0	130.0	100.0	130.0
60"		100.0	130.0	100.0	120.6	100.0	130.0
36"	120"	100.0	130.0	100.0	130.0	100.0	130.0
42"		100.0	130.0	100.0	130.0	100.0	130.0
48"		100.0	130.0	100.0	123.0	100.0	130.0
54"		100.0	130.0	100.0	111.3	100.0	130.0
60"		100.0	129.2	100.0	102.2	100.0	129.2

INTERPOLATION BETWEEN WIDTHS OR HEIGHTS ALLOWED.

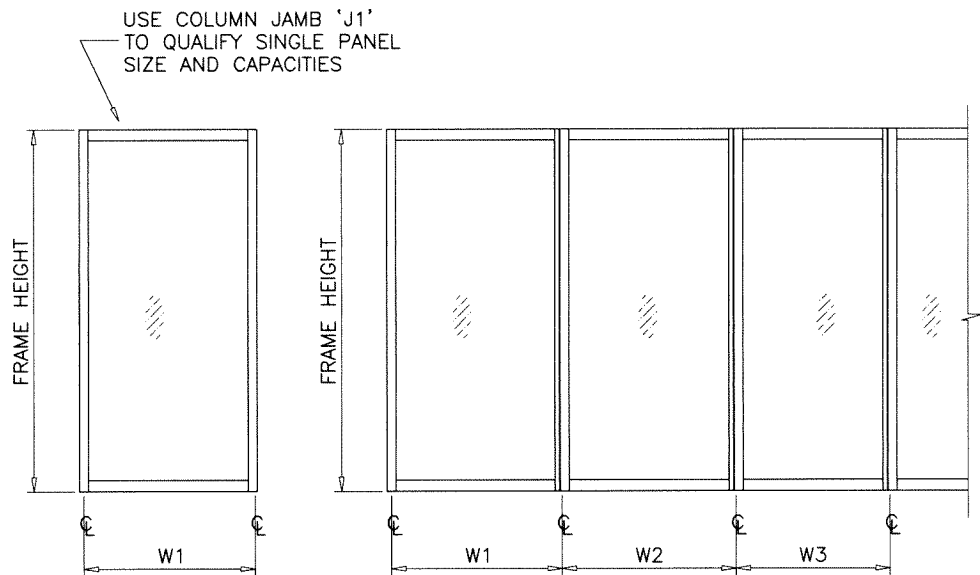

WIDTH (W) = W1
AT FRAME JAMB

WIDTH (W) = $\frac{W2 + W3}{2}$
AT FRAME MULLION

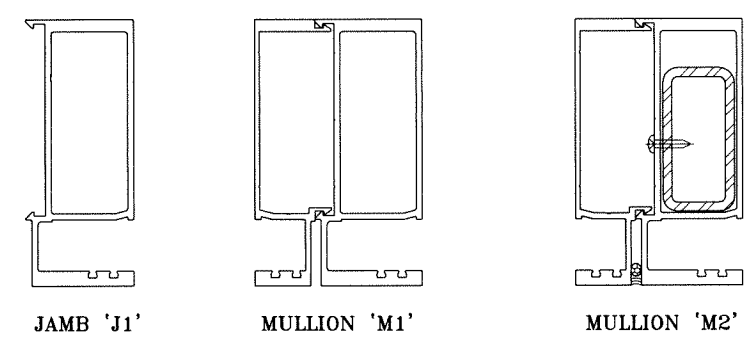

	Ix IN ⁴	Sx IN ³		Ix IN ⁴	Sx IN ³
JAMB 'J1'	10.333	3.546			
MULLION 'M1'	15.440	5.50			
MULLION 'M2'			Ix IN ⁴	Sx IN ³	
ALUMINUM			15.440	5.50	
STEEL			1.42	.945	
TOTAL			18.485		
		Ix ALUM + Ix STL X 2.9			

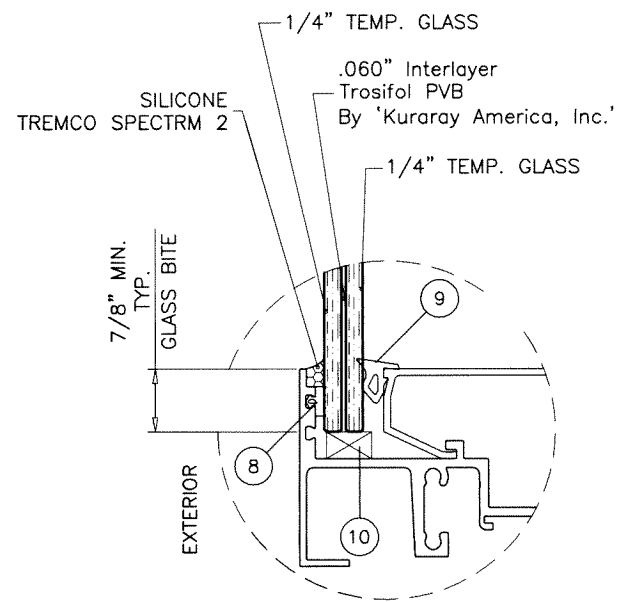

GLAZING DETAIL

NOTE:
GLASS CAPACITIES ON THIS SHEET ARE
BASED ON ASTM E1300-09 (3 SEC. GUSTS).
Sealed: 7/12/2023

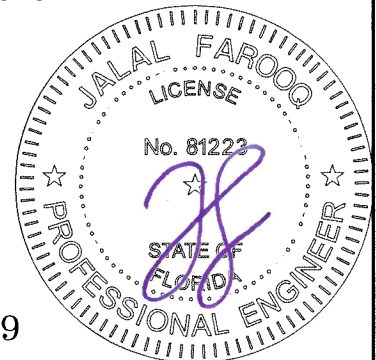

FL #21899

AL-FAROOQ CORPORATION
ENGINEERS & PRODUCT DEVELOPMENT
9360 SUNSET DRIVE, SUITE 220
MIAMI, FLORIDA 33173 (C.A.N. 3538)
TEL. (305) 264-8100 FAX. (305) 262-6978
COMP-ANL\W16-68ECS

RAMPART SERIES 5500 WINDOW WALL (S.M.I.)
EGS INTERNATIONAL, LLC
2799 SW 34th Avenue
Pembroke Park, FL 33023
Phone: (954) 519-7536 www.egsinternationalllc.com

revisions:	no	date	description
date:	11-05-16	scale:	-
dr. by:	TARIQ	chk. by:	
drawing no.	W16-68		
sheet	2 of 7		

JAMB/MULLION ANCHOR LOAD CAPACITY - PSF				
NOMINAL DIMS.		ANCHORS TYPE 'A'	ANCHORS TYPE 'B'	ANCHORS TYPE 'C'
WIDTH (W)	FRAME HEIGHT	EXT. (+) INT. (-)	EXT. (+) INT. (-)	EXT. (+) INT. (-)
36"	72"	130.0	130.0	130.0
42"		130.0	130.0	130.0
48"		117.5	130.0	130.0
54"		104.4	130.0	125.3
60"		94.0	130.0	112.8
66"		85.5	130.0	102.5
72"		78.3	130.0	94.0
36"	78"	130.0	130.0	130.0
42"		124.0	130.0	130.0
48"		108.5	130.0	130.0
54"		96.4	130.0	115.7
60"		86.8	130.0	104.1
66"		78.9	130.0	94.7
72"		72.3	130.0	86.8
36"	84"	130.0	130.0	130.0
42"		115.1	130.0	130.0
48"		100.7	130.0	120.9
54"		89.5	130.0	107.4
60"		80.6	130.0	96.7
66"		73.2	130.0	87.9
72"		67.1	129.4	80.6
36"	90"	125.3	130.0	130.0
42"		107.4	130.0	128.9
48"		94.0	130.0	112.8
54"		83.6	130.0	100.3
60"		75.2	130.0	90.2
66"		68.4	130.0	82.0
72"		62.7	120.8	75.2
36"	96"	117.5	130.0	130.0
42"		100.7	130.0	120.9
48"		88.1	130.0	105.8
54"		78.3	130.0	94.0
60"		70.5	130.0	84.6
66"		64.1	123.5	76.9
72"		58.8	113.3	70.5
36"	102"	110.6	130.0	130.0
42"		94.8	130.0	113.7
48"		82.9	130.0	99.5
54"		73.7	130.0	88.5
60"		66.4	127.9	79.6
66"		60.3	116.3	72.4
36"		108"	104.4	130.0
42"	89.5		130.0	107.4
48"	78.3		130.0	94.0
54"	69.6		130.0	83.6
60"	62.7		120.8	75.2
66"	57.0		109.8	68.4

JAMB/MULLION ANCHOR LOAD CAPACITY - PSF				
NOMINAL DIMS.		ANCHORS TYPE 'A'	ANCHORS TYPE 'B'	ANCHORS TYPE 'C'
WIDTH (W)	FRAME HEIGHT	EXT. (+) INT. (-)	EXT. (+) INT. (-)	EXT. (+) INT. (-)
36"	114"	98.9	130.0	118.7
42"		84.8	130.0	101.8
48"		74.2	130.0	89.1
54"		66.0	127.2	79.2
60"		59.4	114.4	71.2
36"	120"	94.0	130.0	112.8
42"		80.6	130.0	96.7
48"		70.5	130.0	84.6
54"		62.7	120.8	75.2
60"		56.4	108.7	67.7

INTERPOLATION BETWEEN WIDTHS OR HEIGHTS ALLOWED.
SEE SHEET 4 FOR ANCHOR DESCRIPTION.

af c
AL-FAROOQ CORPORATION
 ENGINEERS & PRODUCT DEVELOPMENT
 9360 SUNSET DRIVE, SUITE 220 (C.A.N. 3538)
 MIAMI, FLORIDA 33173 TEL. (305) 262-6978
 FAX. (305) 264-8100
 COMP-ANL W16-68ECS

RAMPART SERIES 5500 WINDOW WALL (S.M.I.)
EGS INTERNATIONAL, LLC
 2799 SW 34th Avenue
 Pembroke Park, FL 33023
 Phone: (954) 519-7536 www.egsinternationalllc.com

revisions:	no.	date	by	description
date:	11-05-16			
scale:	-			
dr. by:	TARIQ			
chk. by:				
drawing no.	W16-68			
sheet	3 of 7			

Sealed: 7/12/2023

ANCHORS

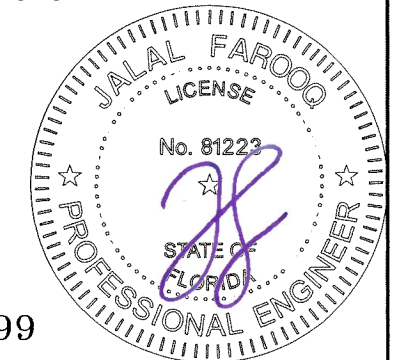

FL #21899

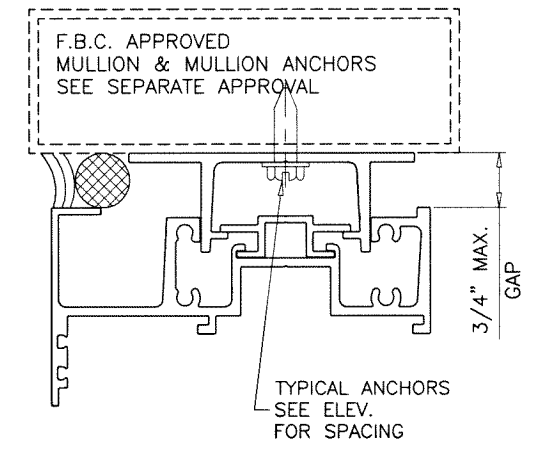
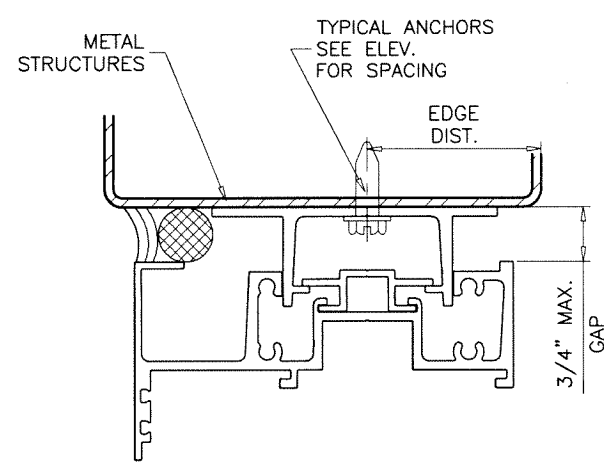
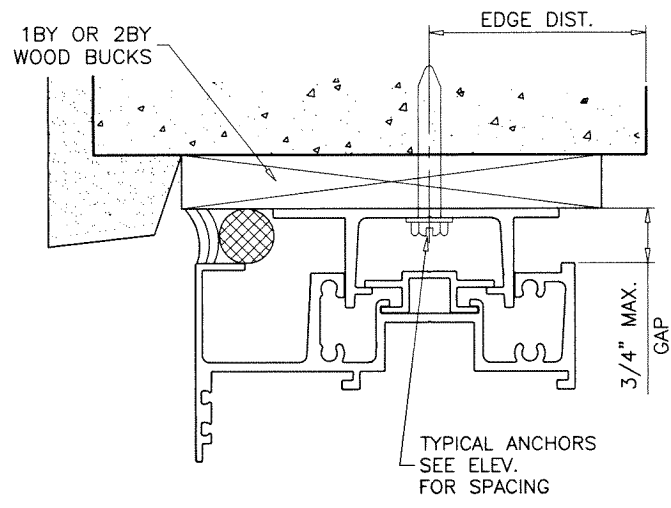
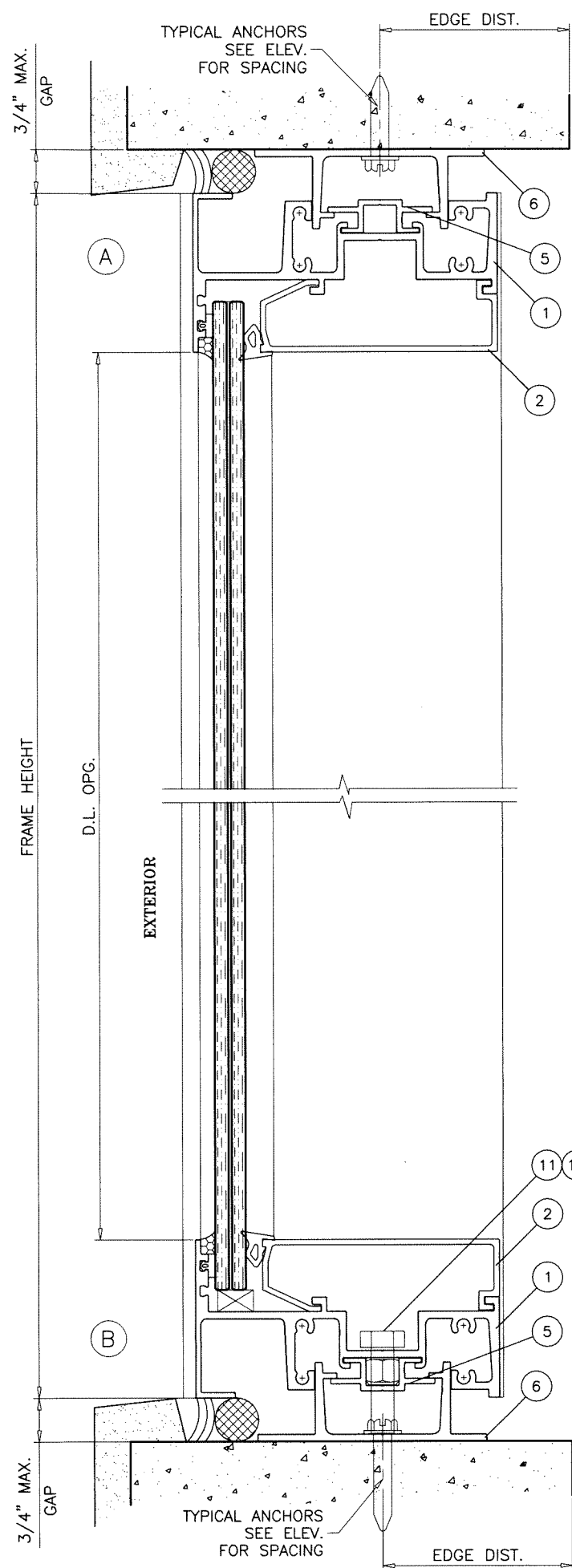

WOOD BUCKS AND METAL STRUCTURE NOT BY 'EGS' MUST SUSTAIN LOADS IMPOSED BY GLAZING SYSTEM AND TRANSFER THEM TO THE BUILDING STRUCTURE.

TYPICAL ANCHORS: SEE ELEV. FOR SPACING

TYPE 'A' - 5/16" DIA ULTRACON BY 'DEWALT' ($F_u=177$ KSI, $F_y=155$ KSI)
 THRU 1BY OR 2BY BUCKS INTO CONCRETE
 1-1/4" MIN. EMBED INTO CONCRETE (HEAD/SILL)

ANCHOR EDGE DISTANCES
 INTO CONCRETE = 2-1/2" MIN.
 INTO WOOD STRUCTURE = 1" MIN.

TYPE 'B' - 5/16" DIA ULTRACON BY 'DEWALT' ($F_u=177$ KSI, $F_y=155$ KSI)
 DIRECTLY INTO CONCRETE
 2" MIN. EMBED INTO CONCRETE (HEAD/SILL)

ANCHOR EDGE DISTANCES
 INTO CONCRETE = 2-1/2" MIN.

TYPE 'C' - 5/16" DIA. TEKS OR SELF DRILLING SCREWS (GRADE 5 CRS)
 INTO F.B.C. APPROVED MULLIONS
 OR
 INTO METAL STRUCTURES (HEAD/SILL)
 (3) THREADS MIN. TO EXTEND BEYOND METAL THICKNESS
 ALUMINUM: 1/8" THK. MIN. (6063-T5 MIN.)
 STEEL: 1/8" THK. MIN. ($F_y = 36$ KSI MIN.)
 (STEEL IN CONTACT WITH ALUMINUM TO BE PLATED OR PAINTED)

ANCHOR EDGE DISTANCES
 INTO METAL STRUCTURE = 1/2" MIN.

WOOD AT HEAD OR SILL SG = 0.55 MIN.
 CONCRETE AT HEAD OR SILL $f'_c = 3000$ PSI MIN.

Sealed: 7/12/2023

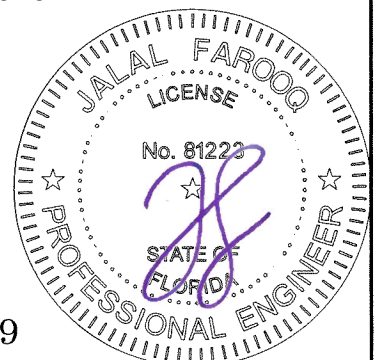

FL #21899

a f c

AL-FAROOQ CORPORATION
 ENGINEERS & PRODUCT DEVELOPMENT
 9360 SUNSET DRIVE, SUITE 220
 MIAMI, FLORIDA 33173 (C.A.N. 3538)
 TEL. (305) 264-8100 FAX. (305) 262-6978
 COMP-ANL\W16-68EGS

RAMPART SERIES 5500 WINDOW WALL (S.M.I.)

EGS INTERNATIONAL, LLC
 2799 SW 34th Avenue
 Pembroke Park, FL 33023
 Phone: (954) 519-7536 www.egsinternationalllc.com

no	date	description

date: 11-05-16
 scale: 3/8" = 1"
 dr. by: TARIQ
 chk. by:

drawing no.
W16-68
 sheet 4 of 7

revisions:	no	date	by	description
date:	11-05-16	scale:	3/8" = 1"	
dr. by:	TARIQ	chk. by:		
drawing no.	W16-68			
sheet	5 of 7			

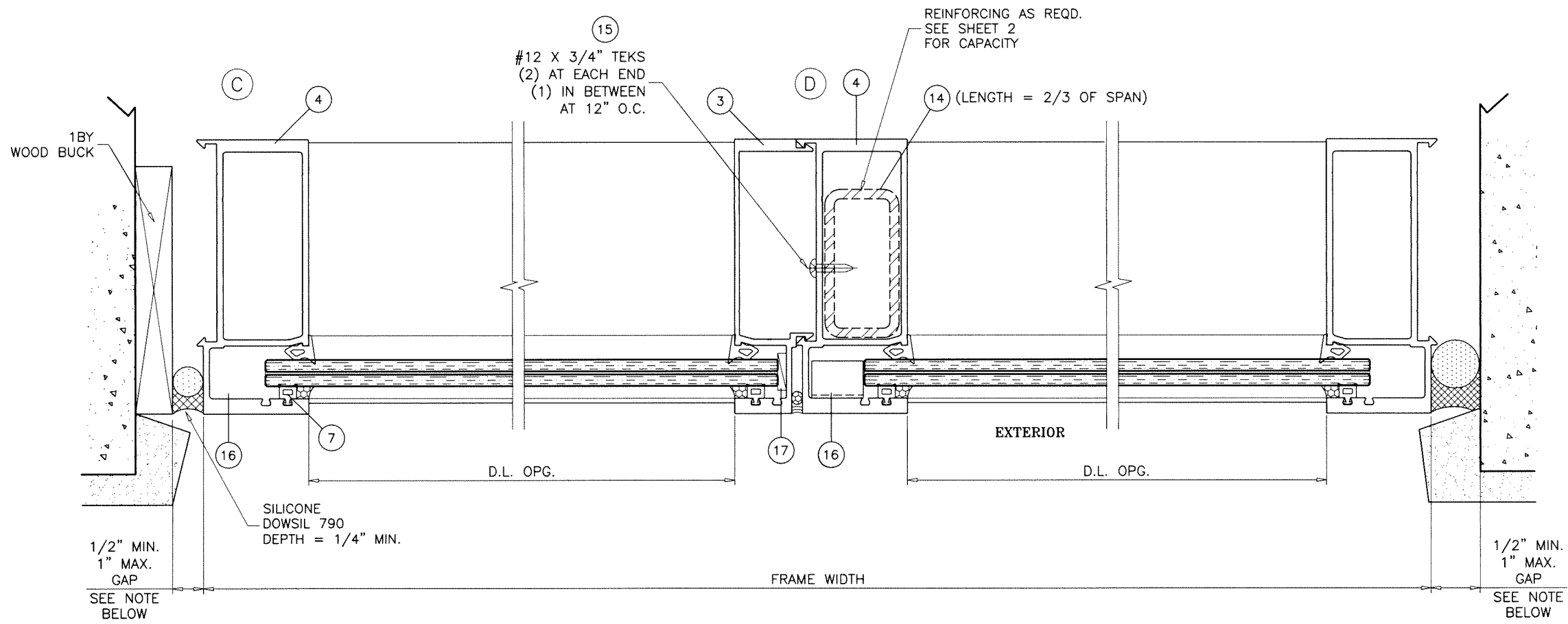

NOTE:
 MAX. MOVEMENT CONSIDERED=100% STRETCH.
 PLEASE REFER TO SEALANT MANUFACTURER'S DATA AND APPLICATION MANUAL FOR COMPATABILITY OF SEALANT TO SUBSTRATE & WINDOW WALL MATERIAL/FINISH AND COMPLIANCE FOR WARRANTY.
 REFER TO ACI-117-10 FOR CONSTRUCTION TOLERANCES.
 ALTERNATE SEALANTS AT JAMB GAPS CAN BE DESIGNED BY ENGINEER OF RECORD BASED ON MANUFACTURER GUIDE LINES.
 GAPS LESS THAN 1/4" MAY BE DESIGNED BY ENGINEER OF RECORD BY THE USE OF BOND BREAKER TAPE OR 15% OF GAP ALLOWED MOVEMENT.

Sealed: 7/12/2023

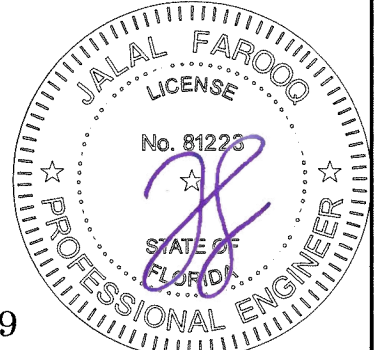

FL #21899

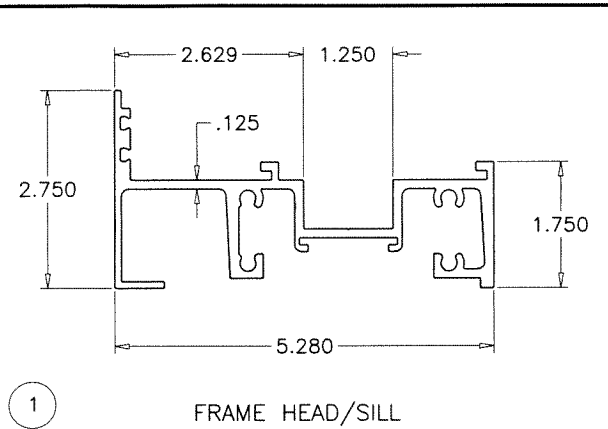

1 FRAME HEAD/SILL

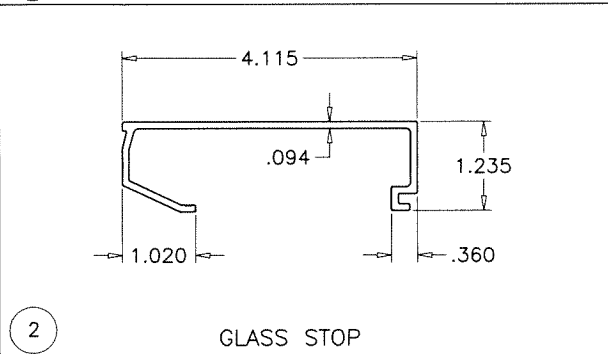

2 GLASS STOP

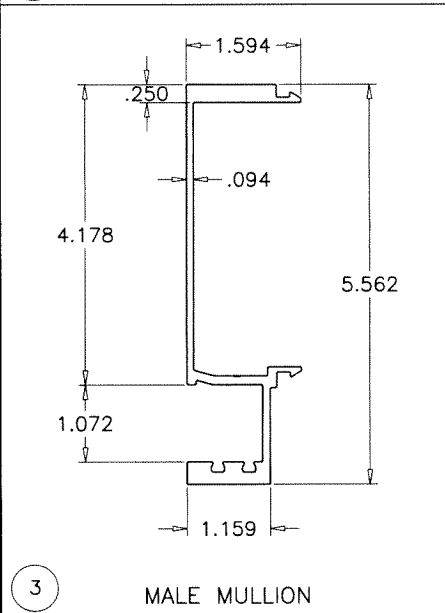

3 MALE MULLION

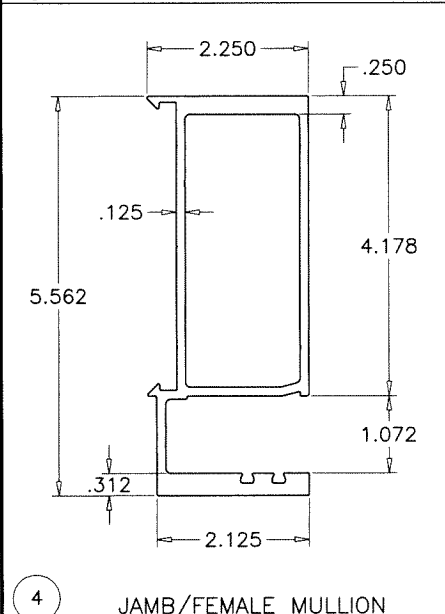

4 JAMB/FEMALE MULLION

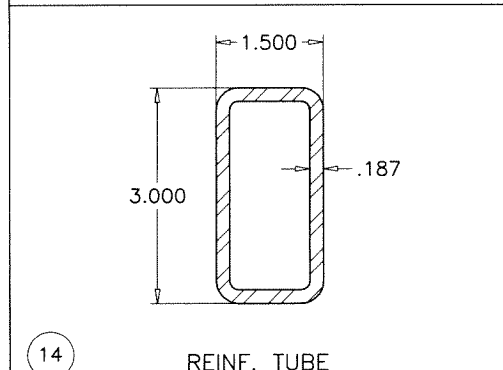

14 REINF. TUBE

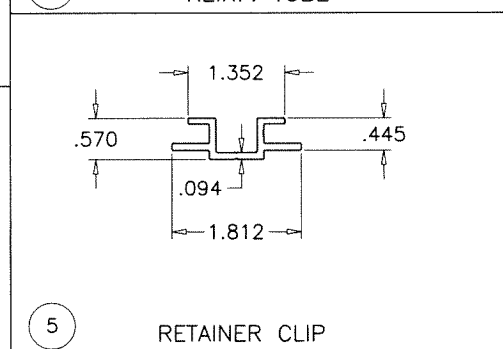

5 RETAINER CLIP

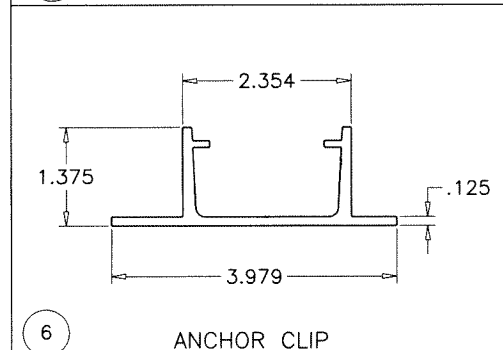

6 ANCHOR CLIP

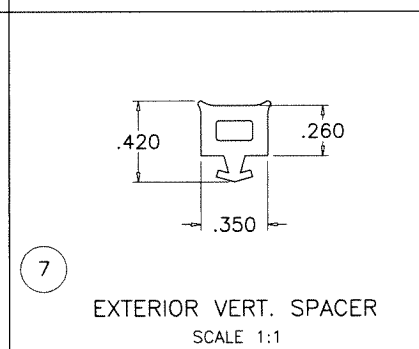

7 EXTERIOR VERT. SPACER
SCALE 1:1

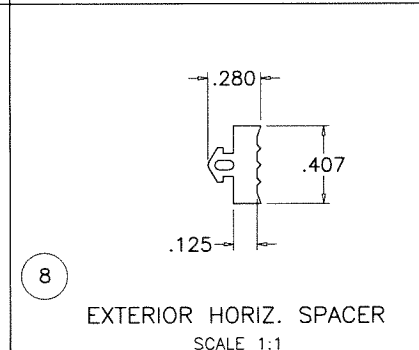

8 EXTERIOR HORIZ. SPACER
SCALE 1:1

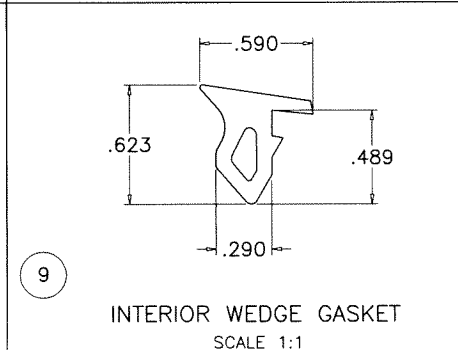

9 INTERIOR WEDGE GASKET
SCALE 1:1

ITEM NO.	PART NUMBER	QUANTITY	DESCRIPTION	MATERIAL	MANF./SUPPLIER/REMARKS
1	EGS-F3	AS REQD.	FRAME HEAD/SILL	6063-T6	-
2	EGS-F4	AS REQD.	GLASS STOP	6063-T5	-
3	EGS-F2	AS REQD.	MALE MULLION	6005-T5	-
4	EGS-F1	AS REQD.	JAMB/FEMALE MULLION	6005-T5	-
5	EGS-F6	AS REQD.	ADJUSTMENT RETAINER CLIP, 3" LONG	6063-T5	-
6	EGS-F5	AS REQD.	ANCHOR CLIP, 12" LONG	6005-T5	-
7	EGS-F7	AS REQD.	EXTERIOR VERT. SPACER	EPDM	TREMCO, DUROMETER 60±5 SHORE A
8	EGS-F8	AS REQD.	EXTERIOR HORIZ. SPACER	EPDM	TREMCO, DUROMETER 70±5 SHORE A
9	EGS-F9	AS REQD.	INTERIOR WEDGE GASKET	EPDM	TREMCO, DUROMETER 70±5 SHORE A
10	EGS-F10	AS REQD.	SETTING BLOCKS AT 1/4 POINTS, 4" LONG	EPDM	GLAZING RUBBER, DUROMETER 80±5 SHORE A
11	3/8-16 X 1-3/4"	1/ CLIP	ADJUSTMENT FASTENER AT SILL	ST. STEEL	-
12	3/8"	1/ CLIP	NYLON LOCK HEX NUT AT SILL	ST. STEEL	-
13	#14 X 1-1/2"	4/ CORNER	ASSEMBLY FASTENERS	ST. STEEL	PH PHIL. SMS
14	HSS3X1-1/2	AS REQD.	REINFORCING TUBE (LENGTH = 2/3 OF MULL HT.)	STEEL	A36
15	#12 X 3/4" TEKS	AS REQD.	REINFORCEMENT TUBE FASTENERS	ST. STEEL	(2) AT EACH END & (1) AT 15" O.C. IN BETWEEN
16	EGS-F12	AS REQD.	3/4" X 3/4" X .062" ANGLE	ALUM	AT TOP & BOTTOM OF JAMBS & MULLIONS
17	EGS-F11	AS REQD.	4" LONG GLASS SPACER, 6" FROM TOP & BOTTOM	EPDM	DUROMETER 80±5 SHORE A

Sealed: 7/12/2023

FL #21899

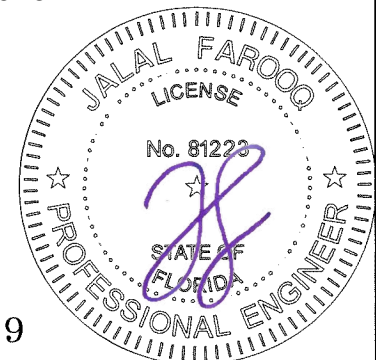

AL-FAROOQ CORPORATION
ENGINEERS & PRODUCT DEVELOPMENT
9360 SUNSET DRIVE, SUITE 220
MIAMI, FLORIDA 33173 (C.A.N. 3538)
TEL. (305) 264-8100 FAX. (305) 262-6978
COMP-ANL\W16-68ECS

RAMPART SERIES 5500 WINDOW WALL (S.M.I.)
EGS INTERNATIONAL, LLC
2799 SW 34th Avenue
Pembroke Park, FL 33023
Phone: (954) 519-7536 www.egsinternationalllc.com

revisions:	no	date	description
date:	11-05-16	scale:	3/8" = 1"
dr. by:	TARIQ	chk. by:	
drawing no.	W16-68		
sheet	6 of 7		

afc

AL-FAROOQ CORPORATION
ENGINEERS & PRODUCT DEVELOPMENT
9360 SUNSET DRIVE, SUITE 220 (C.A.N. 3538)
MIAMI, FLORIDA 33173
TEL. (305) 264-8100 FAX. (305) 262-6978
COMP-ANL\W16-68EGS

RAMPART SERIES 5500 WINDOW WALL (S.M.I.)

EGS INTERNATIONAL, LLC
2799 SW 34th Avenue
Pembroke Park, FL 33023
Phone: (954) 519-7536 www.egsinternationalllc.com

no	date	by	description

date: 11-05-16	scale: 3/8" = 1"
dr. by: TARIQ	chk. by:

drawing no.
W16-68
sheet 7 of 7

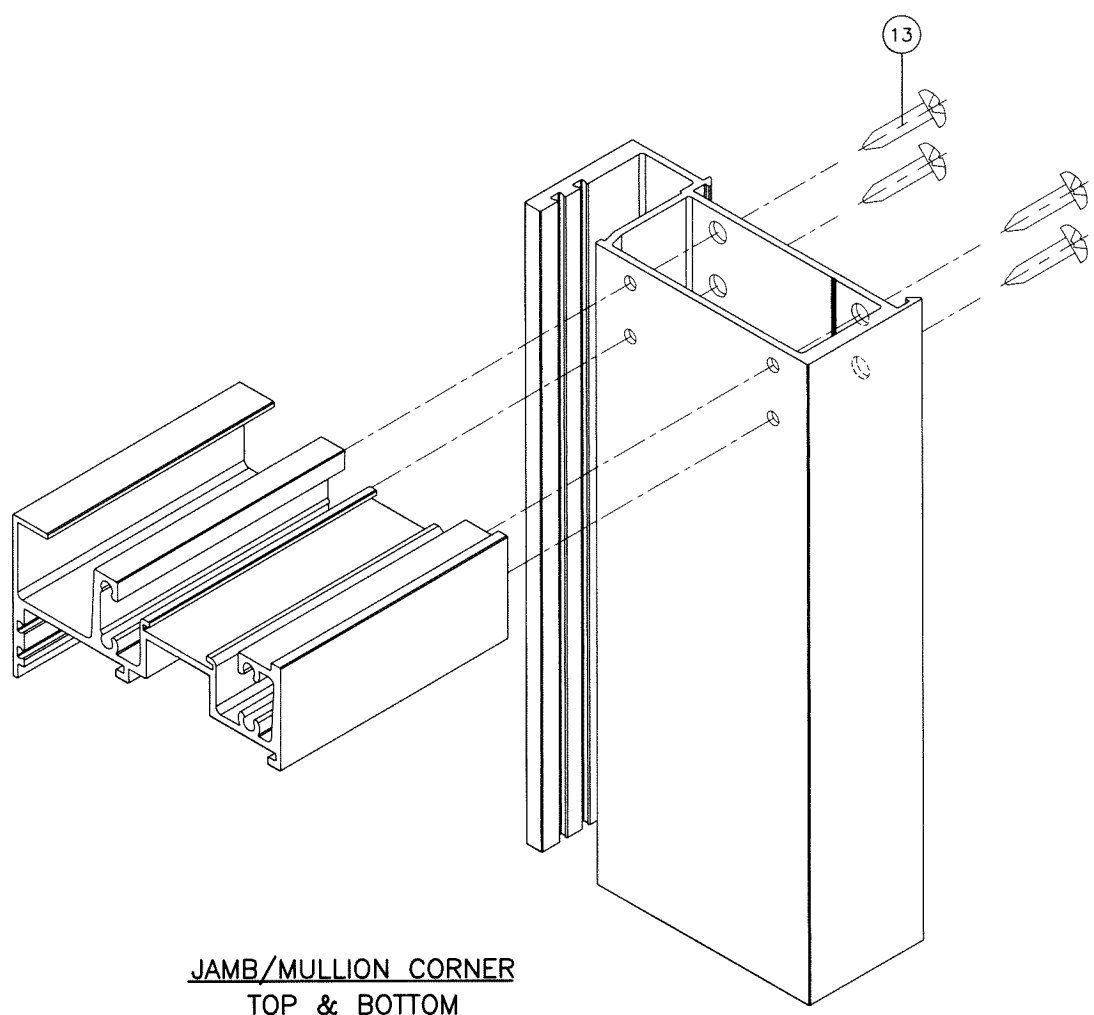

JAMB/MULLION CORNER
TOP & BOTTOM

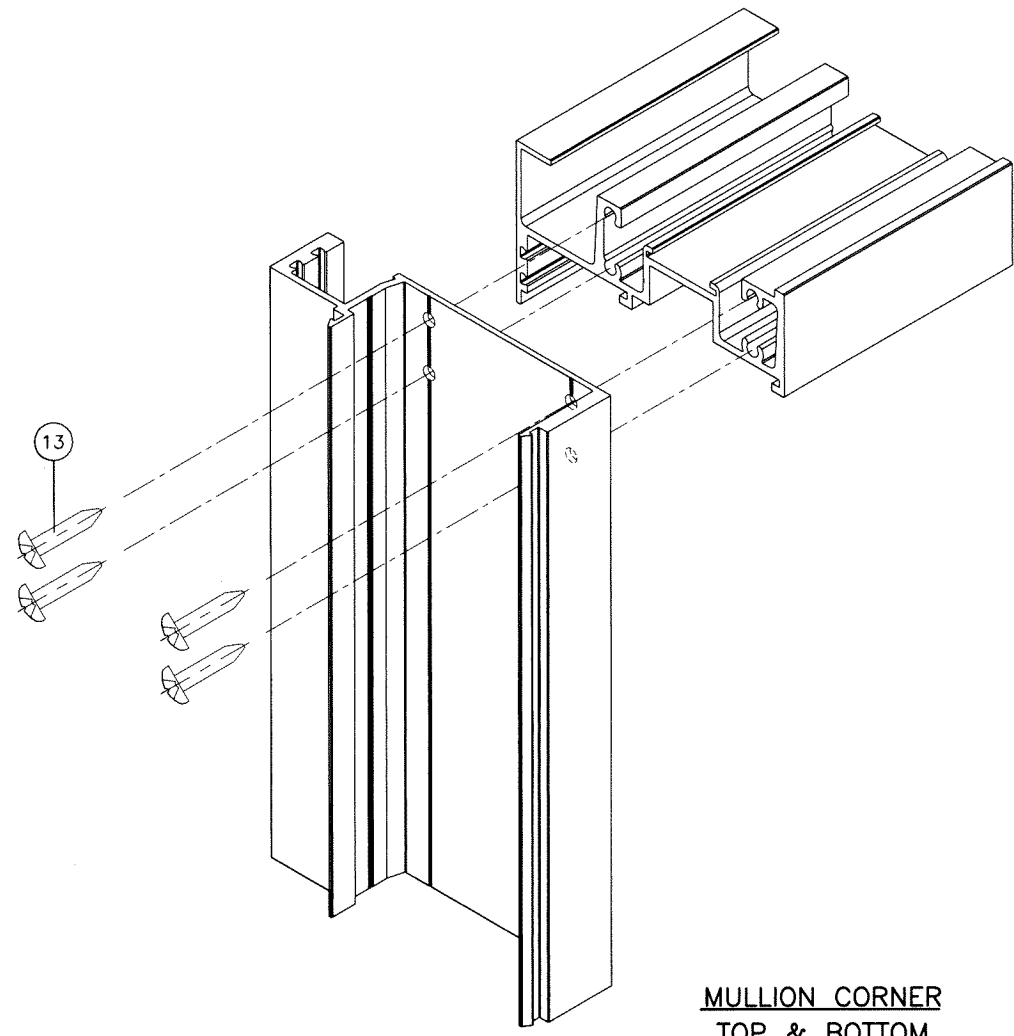

MULLION CORNER
TOP & BOTTOM

Sealed: 7/12/2023

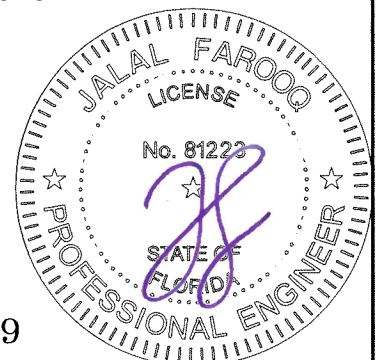

FL #21899